



Small, compact, strong, quiet, oil-free –  
Battery pack-power- horizontal  
drilling rig!



L-Team X-Tools GmbH & Co.  
KG  
Auf den  
Stammäckern 1 D-  
63695 Glauburg

Fon +49 (0) 6041 90 99 01 -  
0  
info@x-tools-  
team.de www.x-  
tools-team.de

## Specifications

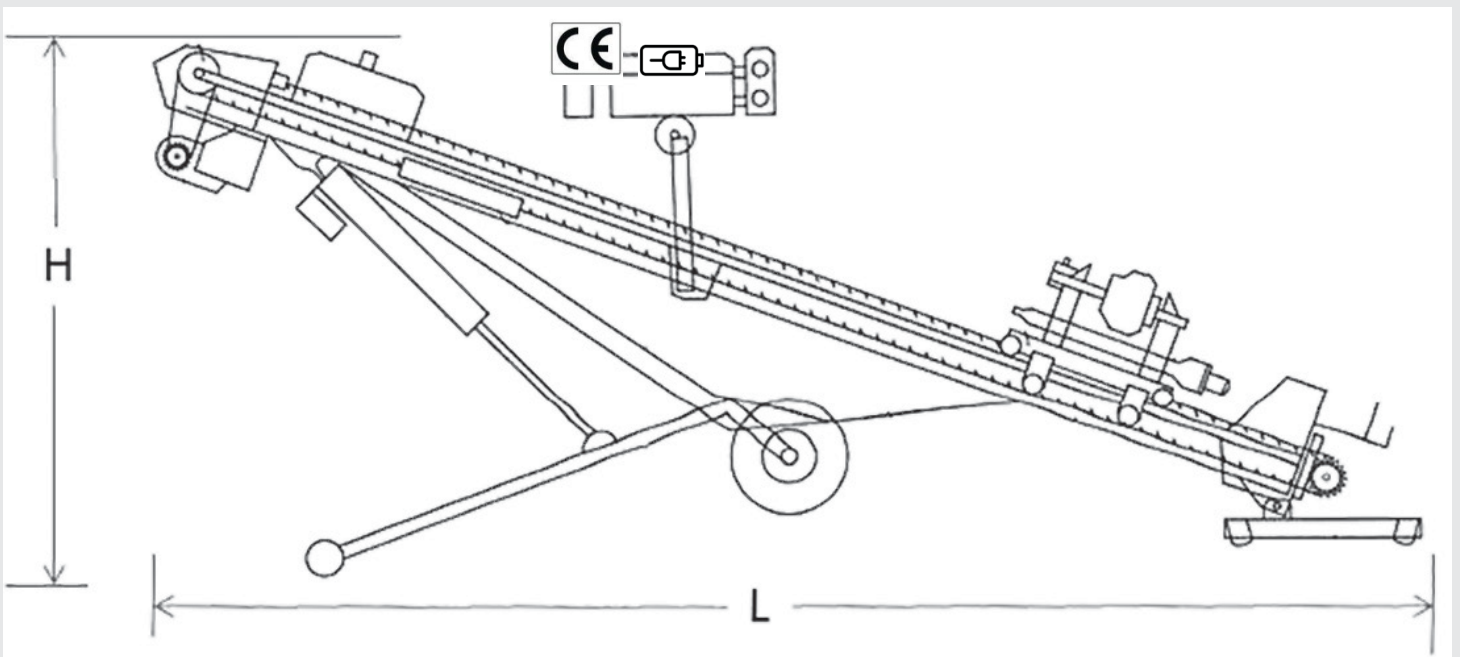

<b>Dimensions</b>	<b>Metric</b>
L, total length, extended	180 cm
retracted	200 cm
B, width	74 cm
H, total height, extended	110 cm
retracted	82 cm
Operating weight	130 kg
Entrance angle	38,7°
Floor loading	75 kg
Ground clear., extended	15 cm
retracted	0
<b>Pipe</b>	
Length of drill pipe, nominal	120 cm
Ø outside tool joint end	30 mm
Ø of drill pipe	30 mm
Bend radius, min.	8 m
Weight of drill pipe	1,25 kg
Weight , pipe box (14 pipe)	17,5 kg
<b>Operation</b>	
Max. Spindle speed, stage 1	43 U/min
stage 2	100 U/min
Max. Spindle torque, stage 1	55 N
Carriage thrust travel speed., stage 1	0,42 m/s
Stage 2	0,97 m/s
Carriage pullback travel speed., stage 1	0,42 m/s
Thrust force	2.158 N
Pullback force	2.158 N
Bore diameter	35 mm
Max. backream diameter	80 mm

<b>Power</b>	<b>Metrisch</b>
E-Motor carriage, output	18 V
E-Motor rotation, output	18 V
Lift-up motor, output	18 V
Pressing power	250 N
Feed-pump, E-power	2.500 W
Mix-pump, E-power	1.000 W
<b>Drilling Fluid System</b>	
Pressure, max	40 bar
Flow, max	18,9 l/min
Drilling fluid tank	700 l
<b>Accumulator</b>	
Main-batterie, output	12 V
elektr. charge	675 Ah
Operating time (permanent load)	9 h
Drill-batterie, output	4x 18 V
elektr. charge	4x 5 Ah
Operating time (permanent load)	4x 1,6 h
<b>Noise level</b>	
Sound pressure level for operator ( $L_{pA}$ ) < 70 dB(A) gemäß ISO 6394, EN62841 Outside noise level < 80 dBA gemäß ISO 6393	
<b>Vibration</b>	
The average vibration transmitted to the operator's hand and body during normal operation does not exceed 2.50 m/s <sup>2</sup> .	